

## PALIER BRIDE POUR AXE A SEMELLE

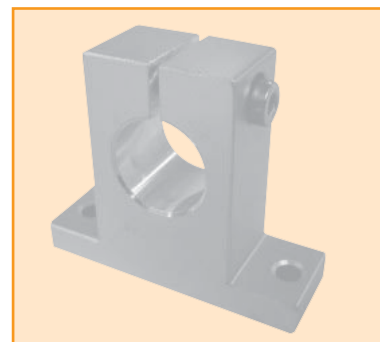
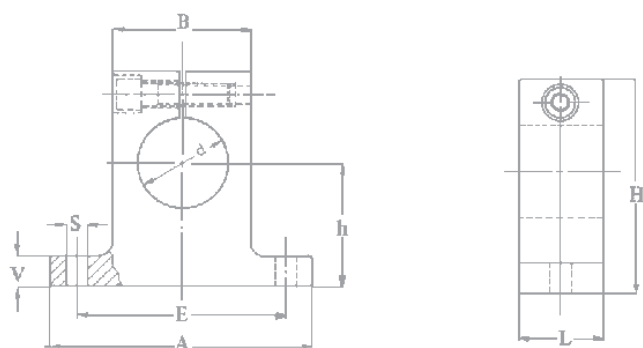

Référence	Dimensions mm									Poids g.
	d H7	h ± 0,015	H	A	E	L	B	S	V	
PA 8	8	15	27	32	25	10	16	3.3	5	20
PA 12	12	20	35	42	32	12	20	4.3	5.5	19
PA 16	16	25	42	50	40	16	26	4.3	6.5	39
PA 20	20	30	50	60	45	20	32	4.3	8	66
PA 25	25	35	58	74	60	25	38	5.3	9	112
PA 30	30	40	68	84	68	28	45	6.4	10	116
PA 40	40	50	86	108	86	32	56	8.4	12	292
PA 50	50	60	100	130	108	40	80	9	14	1 740
PA 60	60	75	124	160	132	48	100	10.5	15	3 600
PA 80	80	100	160	200	170	60	130	13	22	7 300

Matières : Aluminium AS7G06Y33 pour PA 8 au PA 40  
Fonte FLG 250 pour le PA 80

Tolérances sur cote :  
E : PA 8 au PA 25 = ± 0.15 PA 60 = ± 0.25  
PA 30 au PA 50 = ± 0.20 PA 80 = ± 0.50

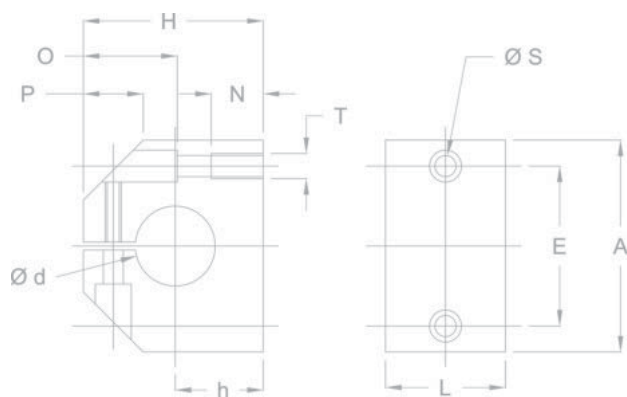

Référence	Dimensions mm												Poids g.
	d H8	h ± 0,015	H	A	L	E	S	T	N	O	P	SW	
PAK 12	12	20	35	42	20	30	5.3	M6	13	16	12	3	60
PAK 16	16	25	42	52	24	38	6.6	M8	18	17	14	3	110
PAK 20	20	30	50	60	30	42	8.4	M10	22	21	19	5	180
PAK 25	25	35	60	76	38	56	10.5	M12	26	25	22	6	350
PAK 30	30	40	70	86	40	64	10.5	M12	26	28	22	6	480
PAK 40	40	50	90	108	48	82	13.5	M16	34	34	30	8	900
PAK 50	50	60	105	130	58	100	17.5	M20	43	40	13	10	1 500
PAKB 12	12	19	33	40	18	27	5.3	M6	13	15	12	3	50
PAKB 16	16	22	38	45	20	32	5.3	M6	13	17	12	3	70
PAKB 20	20	25	45	53	24	39	6.6	M8	18	21	14	4	110
PAKB 25	25	31	54	62	28	44	8.4	M10	22	24	16	5	170
PAKB 30	30	34	60	67	30	49	8.4	M10	22	27	16	5	220
PAKB 40	40	42	76	87	40	66	10.5	M12	26	35	20	6	470

Matière : Alliage d'aluminium 6060-48 -

PAKB : Encombrement réduit